

## Description

The DL0504P5SC is a bi-directional TVS diode, utilizing leading monolithic silicon technology to provide fast re-sponse time and low ESD clamping voltage, making this device an ideal solution for protecting voltage sensitive high-speed data lines. The DL0504P5SC has a low ca-pacitance with a typical value at 0.6pF, and complies with the IEC 61000-4-2 (ESD) with  $\pm 25\text{kV}$  air and  $\pm 15\text{kV}$  con-tact discharge. The small size, low capacitance and high ESD surge protection make DL0504P5SC an ideal choice to protect cell phone, digital visual interfaces, HDMI, DVI, USB2.0, USB3.0, and other high speed ports.

## Features

- ◆ Ultra low capacitance: 0.3pF typical (I/O to I/O)
- ◆ Ultra low leakage: nA level
- ◆ Low operating voltage: 5V
- ◆ Low clamping voltage
- ◆ Up to 4 lines protects
- ◆ Leadless flow-through package
- ◆ Complies with following standards:
  - IEC 61000-4-2 (ESD) immunity test  
Air discharge:  $\pm 25\text{kV}$   
Contact discharge:  $\pm 15\text{kV}$
  - IEC61000-4-4 (EFT) 40A (5/50ns)
  - IEC61000-4-5 (Lightning) : 6A(8/20 $\mu\text{s}$ )
- ◆ ROHS Compliant

## Mechanical Characteristics

- ◆ Package: DFN2510-10 (2.5 x1.0 x0.5mm)
- ◆ Lead Finish: Matte Tin
- ◆ UL Flammability Classification Rating 94V-0
- ◆ Case Material: “Green” Molding Compound
- ◆ Moisture Sensitivity: Level 3 per J-STD-020
- ◆ Terminal Connections: See Diagram Below
- ◆ Marking Information: See Below

## Applications

- ◆ HDMI 1.3 & 1.4, USB 2.0 & 3.0 and MDDI ports
- ◆ Monitors and flat panel displays
- ◆ Set-top box and digital TV
- ◆ Video graphics cards
- ◆ Digital video interface(DVI)
- ◆ Notebook Computers
- ◆ PCI express and Serial SATA ports

## Dimensions and Pin Configuration

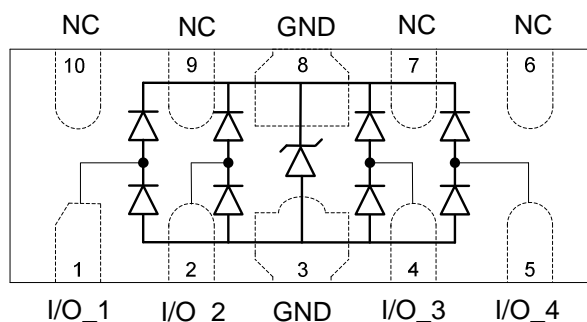

Circuit and Pin Schematic

## Marking Information

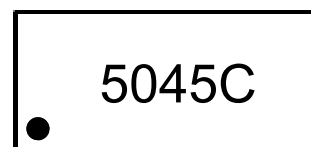

Dot denotes Pin1

## Ordering Information

Part Number	Marking	Packaging	Reel Size
DL0504P5SC	5045C	3000/Tape & Reel	7 inch

**Absolute Maximum Ratings (T<sub>A</sub>=25°C unless otherwise specified)**

Parameter	Symbol	Value	Unit
Peak Pulse Power (8/20μs)	Ppk	50	W
Peak Pulse Current (8/20μs)	I <sub>PP</sub>	6	A
ESD per IEC 61000-4-2 (Air)	V <sub>ESD</sub>	±25	kV
ESD per IEC 61000-4-2 (Contact)		±15	
Operating Temperature Range	T <sub>J</sub>	-55 to +125	°C
Storage Temperature Range	T <sub>stg</sub>	-55 to +150	°C

**Electrical Characteristics (T<sub>A</sub>=25°C unless otherwise specified)**

Parameter	Symbol	Min	Typ	Max	Unit	Test Condition
Reverse Working Voltage	V <sub>RWM</sub>			5	V	Any I/O pin to ground
Breakdown Voltage	V <sub>BR</sub>	6			V	I <sub>T</sub> = 1mA, any I/O pin to ground
Reverse Leakage Current	I <sub>R</sub>			0.2	μA	V <sub>RWM</sub> = 5V, any I/O pin to ground
Clamping Voltage	V <sub>C</sub>		8	10	V	I <sub>PP</sub> = 6A (8 x 20μs pulse), any I/O pin to ground
ESD Clamping Voltage <sup>(1)</sup>	V <sub>C</sub>		2.8		V	I <sub>PP</sub> = 4A, t <sub>p</sub> = 0.2/100ns (TLP), any I/O pin to ground
			5.1		V	I <sub>PP</sub> = 16A, t <sub>p</sub> = 0.2/100ns (TLP), any I/O pin to ground
Dynamic Resistance <sup>(2)</sup>	R <sub>DYN</sub>		0.19		Ohm	t <sub>p</sub> = 0.2/100ns (TLP), any I/O pin to ground
Junction Capacitance	C <sub>J</sub>		0.6		pF	V <sub>R</sub> = 0V, f = 1MHz, any I/O pin to ground

(1) Transmission Line Pulse Test (TLP) Settings: t<sub>p</sub> = 100ns, t<sub>r</sub> = 0.2ns.

(2) Dynamic resistance calculated from I<sub>TLP</sub> = 4A to I<sub>TLP</sub> = 16A.

**Typical Performance Characteristics (TA=25°C unless otherwise Specified)**

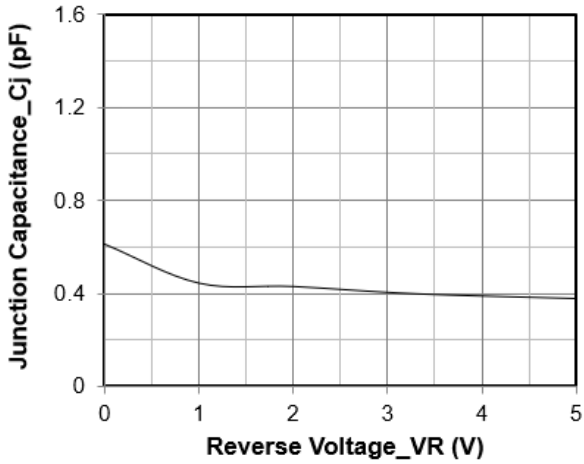

Junction Capacitance vs. Reverse Voltage

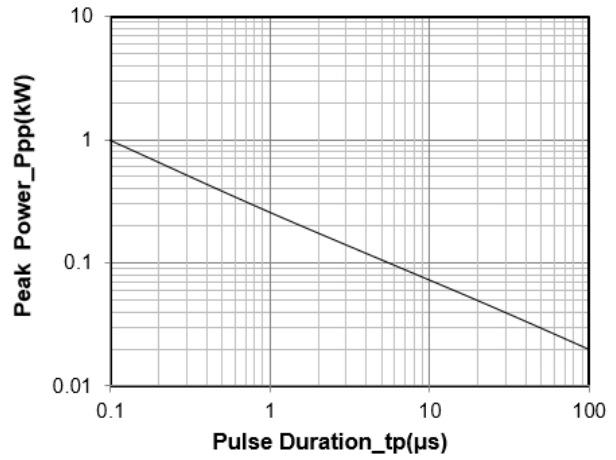

Peak Pulse Power vs. Pulse Time

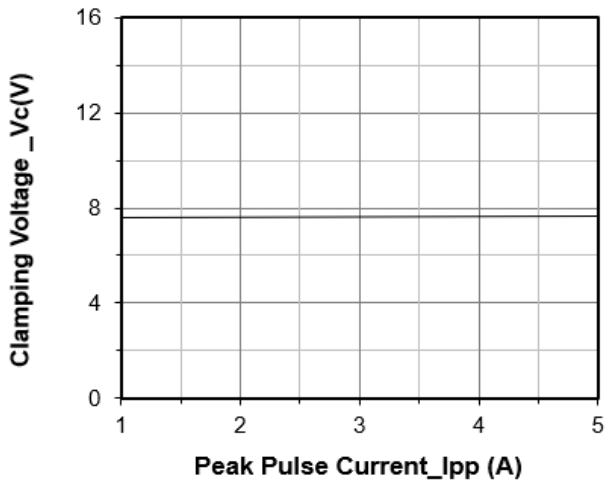

Clamping Voltage vs. Peak Pulse Current (tp = 8/20μs)

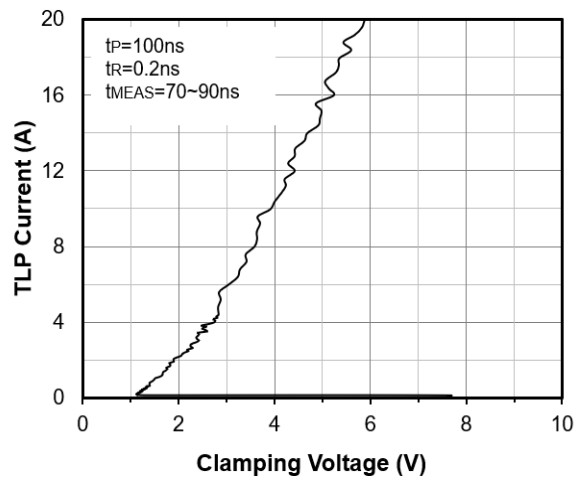

TLP Measurement

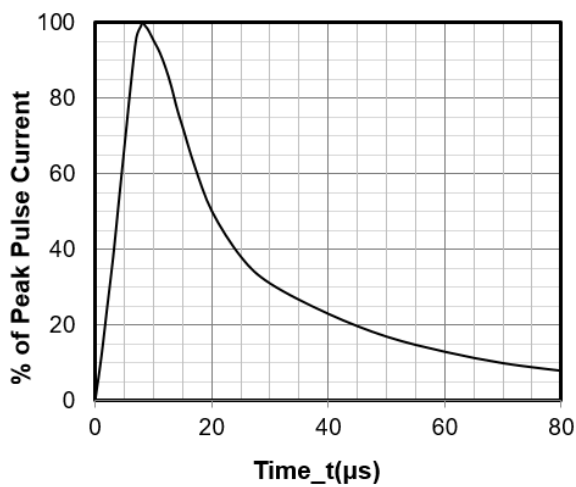

8 X 20μs Pulse Waveform

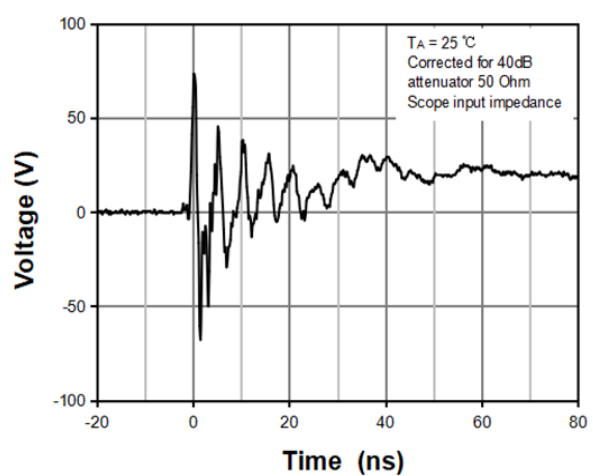

ESD Clamping Voltage  
8 kV Contact per IEC61000-4-2

## DFN2510-10 Package Outline Drawing

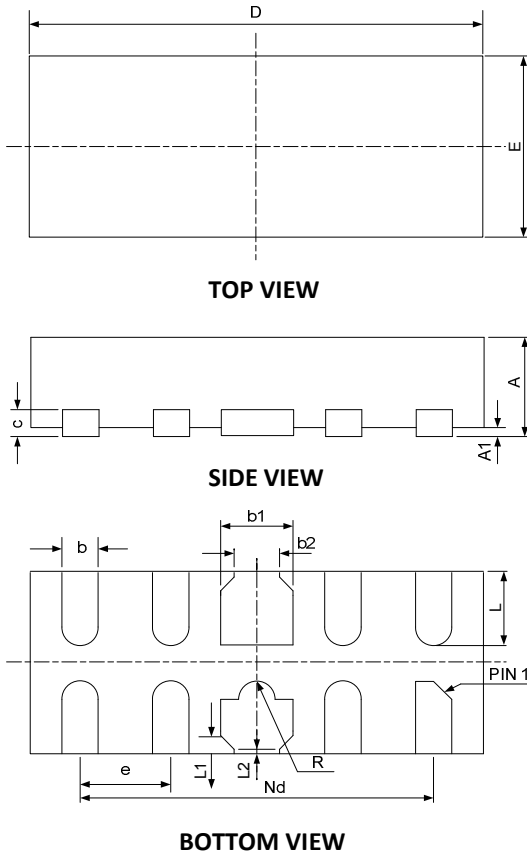

SYM	DIMENSIONS					
	MILLIMETERS			INCHES		
	MIN	NOM	MAX	MIN	NOM	MAX
A	0.45	0.50	0.55	0.018	0.020	0.022
A1	0.00	0.02	0.05	0.000	0.001	0.002
b	0.15	0.20	0.25	0.006	0.008	0.010
b1	0.35	0.40	0.45	0.014	0.016	0.018
b2	0.20	0.25	0.30	0.008	0.010	0.012
c	0.10	0.15	0.20	0.004	0.006	0.008
D	2.45	2.50	2.55	0.098	0.100	0.102
e	0.50BSC			0.020BSC		
Nd	2.00BSC			0.080BSC		
E	0.95	1.00	1.05	0.038	0.040	0.042
L	0.35	0.40	0.45	0.014	0.016	0.018
L1	0.075REF			0.003REF		
L2	0.050REF			0.002REF		
h	0.08	0.12	0.15	0.003	0.005	0.006
R	0.05	0.10	0.15	0.002	0.004	0.006

## Suggested Land Pattern

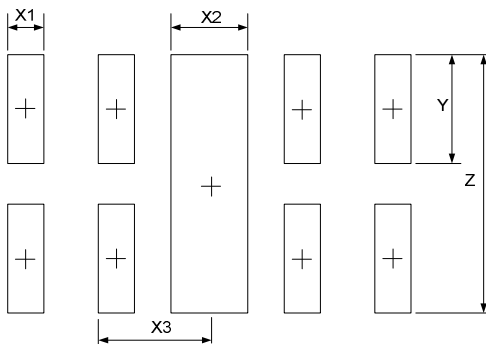

SYM	DIMENSIONS	
	MILLIMETERS	INCHES
X1	0.200	0.008
X2	0.400	0.016
X3	0.500	0.020
Y	0.600	0.024
Z	1.400	0.056

## Contact Information

Changzhou D-first Electronics CO.,Ltd.

[www.first-electronic.com](http://www.first-electronic.com)

Email: [xhf@first-electronic.cn](mailto:xhf@first-electronic.cn)

Phone: +86 (0519) -8817 1671